

**Facility Power**  
208-240VAC, 1Ø, 50/60Hz  
MCA 30A, Max OCPD 40A

- Notes**
1. OCPD must be installed immediately upstream of this equipment.
  2. If a transformer is used, its secondary must be grounded/bonded. Floating secondaries or floating neutrals are not permitted. Neutral must not be connected to this equipment.
  3. For 4500W x-ray tube configurations, MCA, max OCPD, and required conductor size may increase - consult factory.

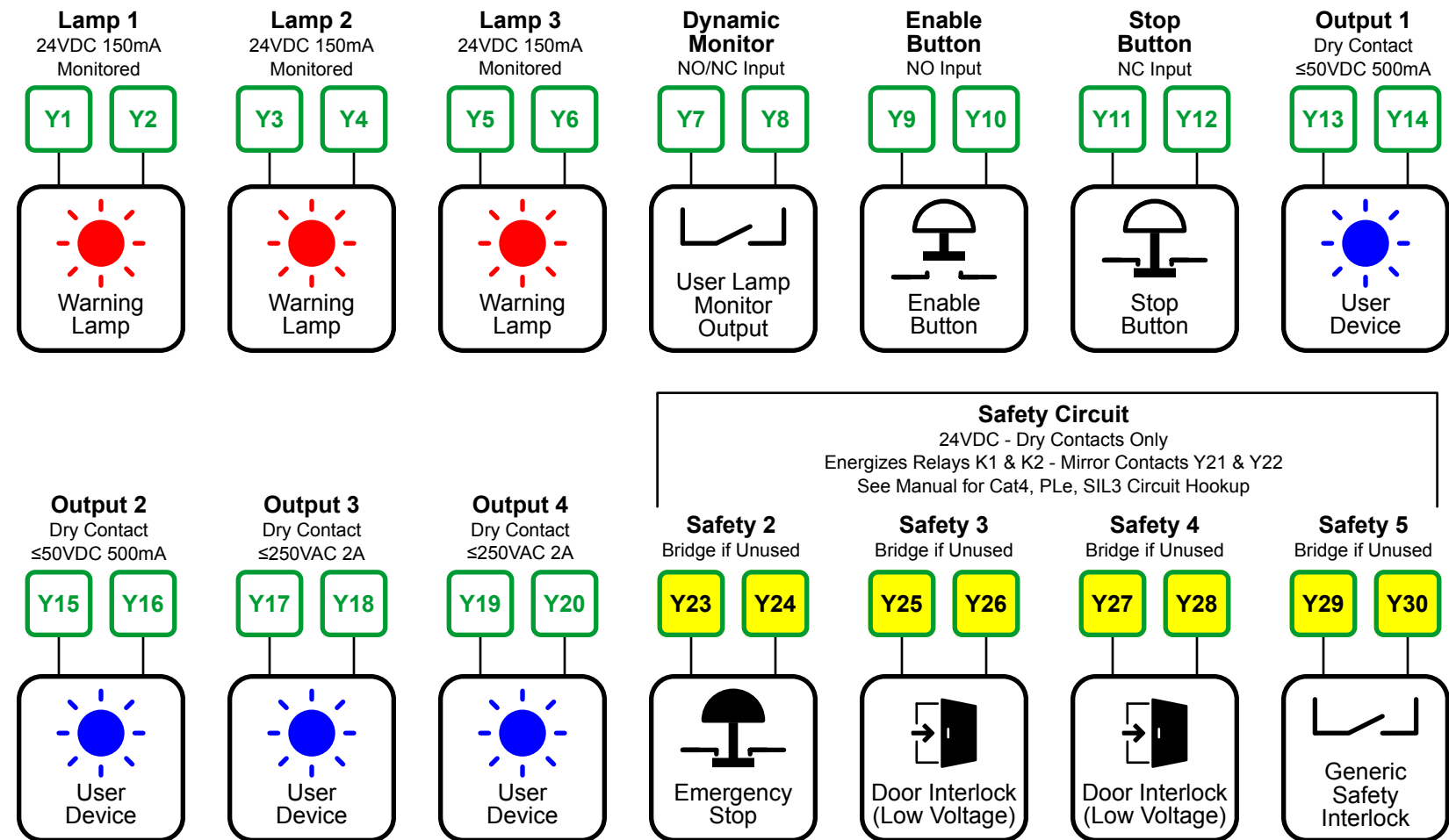
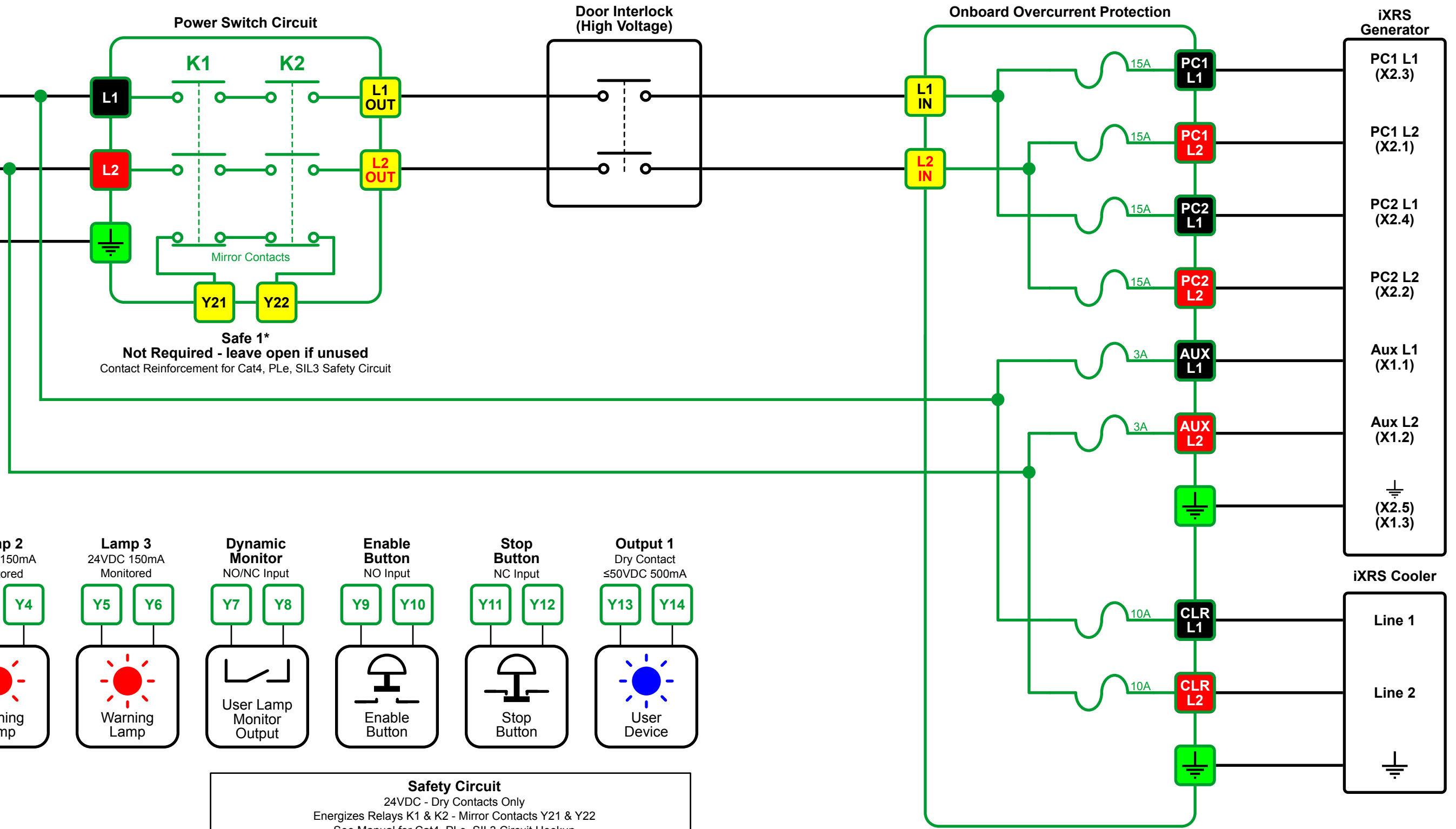

**Safety Circuit**  
24VDC - Dry Contacts Only  
Energizes Relays K1 & K2 - Mirror Contacts Y21 & Y22  
See Manual for Cat4, PLe, SIL3 Circuit Hookup

iVario Breakout Components

Off-Board Components